



TRAXDA
Lift Kits - Made in USA

Toll free: 888-660-5892
email: info@traxda.com

SAFETY WARNING!
Always use the correct tools, and wear safety goggles. We **STRONGLY** recommend installation by a licensed mechanic on a properly secured locking lift.

TIRE FITMENT ADVICE
The best way to ensure proper tire fitment is to install the kit before purchasing your wheels and tires. Always test fit tires and wheels before purchasing.

VEHICLE RIDE WARNING!
Trucks with lift or level kits installed have a higher center of gravity. Aggressive and sudden direction changes may cause a tip over.

604012 Lift and Level Kit
Dodge Ram 1500 4WD

This kit contains:

- 2- Spring Pre-load Spacers
- 2- Upper Strut Spacers
- 2- Rear Spring Spacers
- Instructions
- Warranty Card
- Stickers



Installation Tips

Always use caution handling ABS or wheel sensor wiring. Avoid tension of any kind on wiring harness as this may cause damage or failure.

1. Trucks are often not level side to side from the factory. Please measure before installation.
2. Re-torque all hardware to manufactures specifications
3. When aligning, to get the best tire wear use our supplied specifications. OEM specifications are for trucks with stock wheels and tires. Larger tires will wear differently.
4. All instructions are written with vehicle on a 2-post lift with tires removed.

Step 1

Loosen and remove the upper ball joint nut, tie rod nut, and sway bar nut.
A hammer may be needed to break the ball joint and tie rod free.

Special Note:

On 4X4 models you must remove the drive axle nut. **Failure to follow this step will make removal of the strut difficult.**

Step 2

Remove the strut from the vehicle and **mark the strut for proper re-assembly.** Using a spring compressor tool, disassemble the strut and install the TRAXDA spacer.

*Refer to Figure A for proper placement.

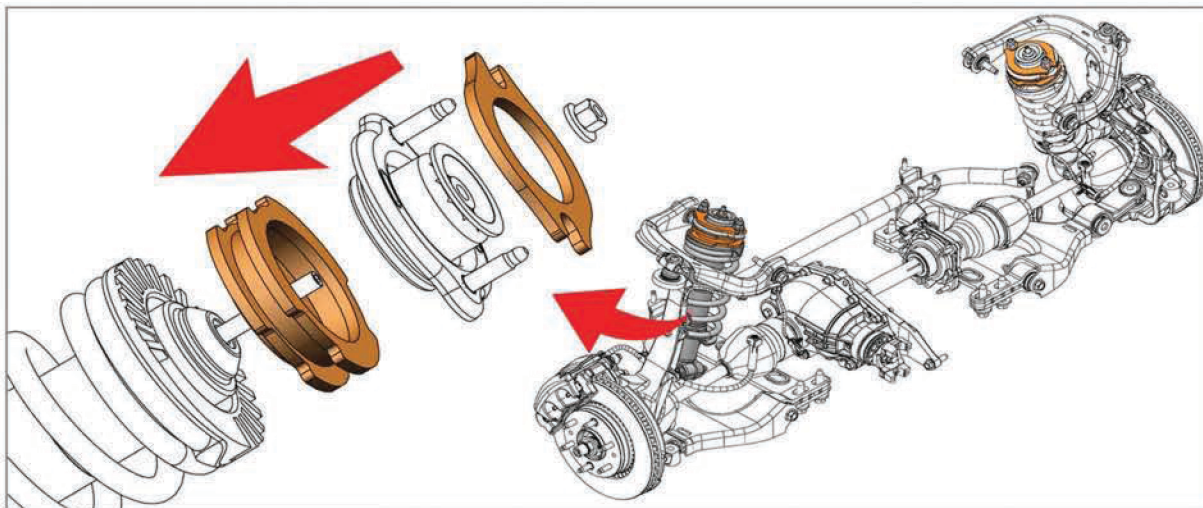

Figure A

Illustration is for reference only. Part dimensions will vary from kit to kit.

Instructions continued on back.



TRAXDA
Lift Kits - Made in USA

Toll free: 888-660-5892
email: info@traxda.com

SAFETY WARNING!
Always use the correct tools, and wear safety goggles. We **STRONGLY** recommend installation by a licensed mechanic on a properly secured locking lift.

TIRE FITMENT ADVICE
The best way to ensure proper tire fitment is to install the kit before purchasing your wheels and tires. Always test fit tires and wheels before purchasing.

VEHICLE RIDE WARNING!
Trucks with lift or level kits installed have a higher center of gravity. Aggressive and sudden direction changes may cause a tip over.

604012 Dodge 1500 4x4 TRAXDA Installation Instructions (cont.)

Rear Installation

Support the weight of the rear axle and remove one rear shock. Be careful of the brake hoses they will be at maximum extension while installing this piece. With the shock removed the spring should come out easily. Install the TRAXDA spring spacer into the vehicle as shown in Figure B using the supplied 10mm bolt. Fit the cone shaped bump stop onto the spacer and have an assistant use a pry bar to lever the spring back into place. Reinstall the shock and repeat on the other side.

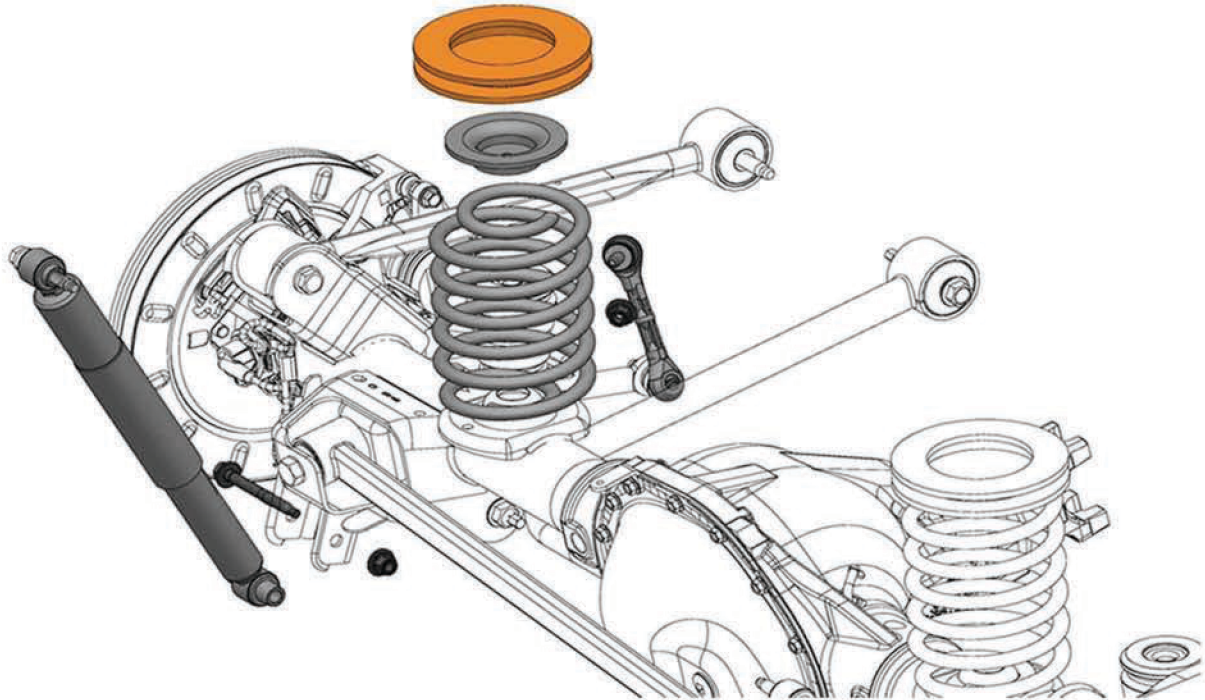

Alignment notes:

We recommend that a technician with experience doing alignments on lifted trucks perform the alignment. Large tires wear differently than OEM sized tires. Always do an alignment after changing tires on a vehicle.

	Left	Right
Caster (degrees)	3.5	4
Camber (degrees)	0	-0.25
Toe	1/16 or .0625	
Special Tools	none	