

404035 LIFT KIT



1999-2007 Chevrolet/GM CLASSIC 4X4 PICKUP 6-Lug Level Kit



THIS KIT CONTAINS

- Torsion Keys (x2)
- Shock Brackets (x2)
- Hardware Pack (x1)
- Rear Lift Blocks (x2)
- U-Bolts (x4)
- U-Bolt Hardware Pack (x1)

Instructions
Stickers

FRONT INSTALLATION

1) Remove torsion key adjusting bolt. Using a torsion bar release tool (or similar c-clamp type ball joint press), apply pressure to the torsion key so the keeper nut in the cross member can be removed. Release pressure from torsion key and slide torsion bar forward allowing key to be removed.

2) Remove lower shock mount bolt and install supplied shock mount bracket and reattach shock.

3) Install TRAXDA torsion key using torsion bar tool, apply pressure to torsion key and install keeper and adjusting bolt. **IMPORTANT** the torsion bar must extend completely through key at least 1/4"

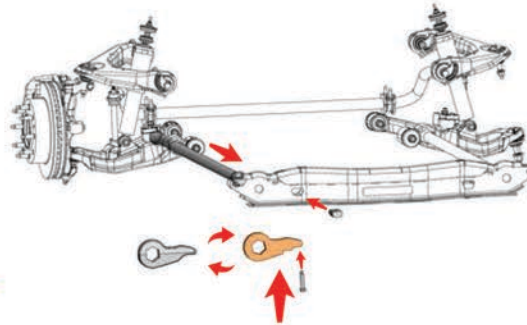

REAR INSTALLATION

Disconnect ABS wire so they can droop. Loosen lower shock bolt and remove. Use a pit jack to support the differential. Remove U-bolts from one side of the truck only. This will help keep the differential steady. Remove factory block and install TRAXDA lift block between differential and leaf spring as shown in Figure B. Install U-bolts supplied with TRAXDA kit. Reinstall lower shock bolts. Repeat on the other side of the truck.

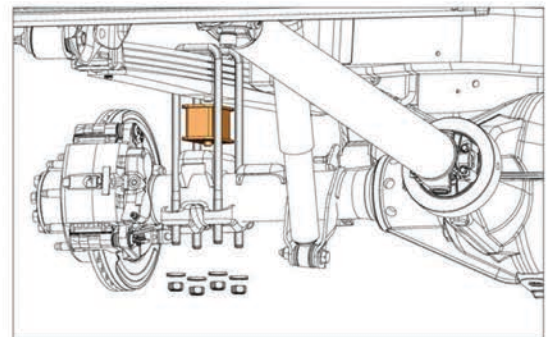

SAFETY WARNING

Always use the correct tools and wear safety goggles. We strongly recommend installation by a licensed mechanic on a properly secured locking lift.

VEHICLE RIDE WARNING

Trucks with lift or level kits installed will have higher centers of gravity than stock. Aggressive driving and sudden direction changes can cause an unexpected rollover.

TIRE FITMENT ADVICE

The best way to ensure proper tire fitment is to install the kit before purchasing your wheels and tires. Always test fit tires and wheels before purchasing.

INSTALLATION TIPS:

Trucks are often not level side to side from the factory. Always measure before installation.

Always re-torque all hardware to the manufacturer's original specifications.

In order to get the best tire wear, use our supplied alignment specifications. OEM specifications are for trucks with stock wheels and tires. Larger tires will wear differently.

All instructions are written for vehicle on a two-post lift with tires removed.

Always use caution when handling ABS or wheel sensor wiring. Avoid tension of any kind on wiring harness as this may cause damage or failure.

	Left	Right
Caster (degrees)	2	2.5
Camber (degrees)	0	-1/4 or -.25
Toe	1/32 or .03125 inch toe in	
Special Tools	none	

Alignment Notes:

We recommend that a technician with experience doing alignments on lifted trucks perform the alignment. Large tires wear differently than OEM sized tires. Always do an alignment after changing tires on a vehicle.