



TRAXDA
Lift Kits - Made in USA

Toll free: 888-660-5892
email: info@traxda.com

SAFETY WARNING!
Always use the correct tools, and wear safety goggles. We **STRONGLY** recommend installation by a licensed mechanic on a properly secured locking lift.

TIRE FITMENT ADVICE
The best way to ensure proper tire fitment is to install the kit before purchasing your wheels and tires. Always test fit tires and wheels before purchasing.

VEHICLE RIDE WARNING!
Trucks with lift or level kits installed have a higher center of gravity. Aggressive and sudden direction changes may cause a tip over.

106036 Ford Expedition Rear Lift Kit

This kit contains:
2 - Strut Caps
1 - Hardware Pack
Instructions
Warranty Card
Stickers



Installation Tips

Always use caution handling ABS or wheel sensor wiring. Avoid tension of any kind on wiring harness as this may cause damage or failure.

1. Trucks are often not level side to side from the factory. Please measure before installation.
2. Re-torque all hardware to manufactures specifications
3. When aligning, to get the best tire wear use our supplied specifications. OEM specifications are for trucks with stock wheels and tires. Larger tires will wear differently.
4. All instructions are written with vehicle on a 2-post lift with tires removed.

Rear Installation

Step 1

Use caution with any ABS wiring to prevent damage. Disconnect tie rod end from spindle assembly, and loosen lower control arm bolts at frame so spindle assembly can swing down and out of the way. Remove lower strut mounting bolt and upper strut mount nuts and remove strut.

Step 2

Install TRAXDA spacer on the strut. Note the twisted shape of the TRAXDA cap, the strut will be rotated 180° when reinstalled. Reinstall the strut assembly in reverse of dis-assembly. A pry bar may aid in installation of the strut. A pit jack may be needed to raise the lower control arm and re-connect ball joint. Verify that all hardware has been tightened to the proper torque specs.

Alignment notes:

We recommend that a technician with experience doing alignments on lifted trucks perform the alignment. Large tires wear differently than OEM sized tires. Always do an alignment after changing tires on a vehicle.

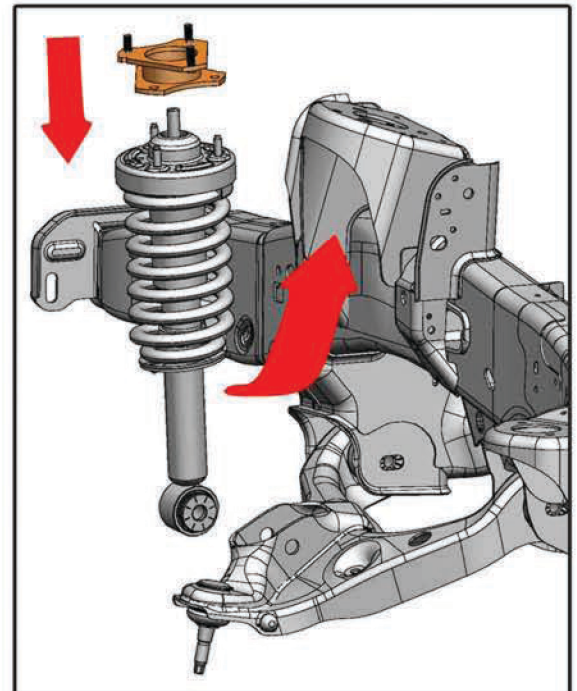

Figure A: Illustration is for reference only. Part dimensions will vary from kit to kit.

	Left	Right
Caster (degrees)	3	3.5
Camber (degrees)	0	-1/4 or -.25
Toe	1/32" or .03125 toe in	
Special Tools	none	